

SCREEN PRINTING AREA

MAXIMUM HEIGHT: 3.325 [84.46]
 MAXIMUM WIDTH: 8.106 [205.89]
 (LEAVING 1/4 [212.24] BREAK IN COPY)

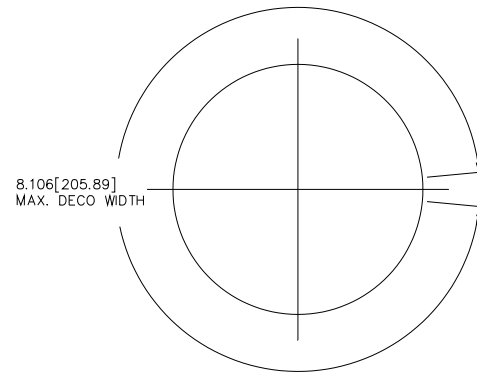

CUSTOM BOTTLE APPROVAL:
 APPROVED BY: [Signature]
 DATE: [Date]

NO.	REV.	BY	DESCRIPTION	DATE	
NECK FINISH:		M24	SP410	GRAM WT. 29±1.5	
'T'	'E'	'H'	'S'	'L'	'I'
.932 ±.008	.848 ±.008	.646 ±.015	.046 ±.015	.437 MIN.	
23.67 ±0.20	21.54 ±0.20	16.41 ±0.38	1.17 ±0.38	11.10 MIN.	
HELIX A:	2° 34'	T.P.I.:	8	CUTT. DIA.:	.375 [9.53]
CAPACITY TO FILL LEVEL BEFORE DECORATING				355ml±9	
CAPACITY TO FILL LEVEL AFTER DECORATING					
OVERFLOW CAPACITY BEFORE DECORATING				402ml±11	
OVERFLOW CAPACITY AFTER DECORATING					



Custom Bottle Inc.
 10 Great Hill Road
 P.O. Box 720
 Naugatuck, Connecticut 06770
 203-723-6681

DRAWN BY: 002	DESC.: 12oz BOSTON RD.
SCALE: 1-1	DATE: JAN.23/06
BOTTLE MAT'L: HDPE	DRAWING NO.: 107-7198-P
CAD NAME: PD\7XXX\107-7198	C.B.I.D.: #275

This drawing subject to standard industry tolerances S.P.I.