

DISCLAIMER: CUSTOM BOTTLE INC.
ASSUMES NO RESPONSIBILITY FOR:
-FORM, FIT AND FUNCTION OF CLOSURES
-SHELF LIFE AND/OR COMPATIBILITY OF
INTENDED CONTENTS WITH THIS BOTTLE.

'T' AND 'E' DIMENSIONS ARE THE
AVERAGE OF TWO MEASUREMENTS
TAKEN 90° APART.
THE LIMITS OF QUALITY WILL BE
DETERMINED PER APPLICATION AS
NECESSARY.

DIMENSIONS IN [] ARE
IN MILLIMETERS
ALL OTHERS INDICATED
ARE IN INCHES
This drawing subject to
standard industry tolerances
S.P.I.

CUSTOM BOTTLE
APPROVAL:
APPROVED BY **BP**
DATE **NOV. 23/10**
CUSTOMER
APPROVAL:
APPROVED BY
DATE

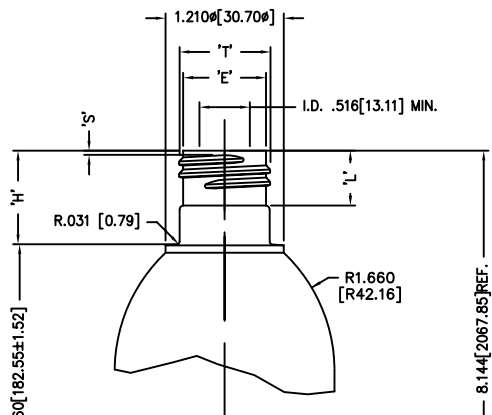
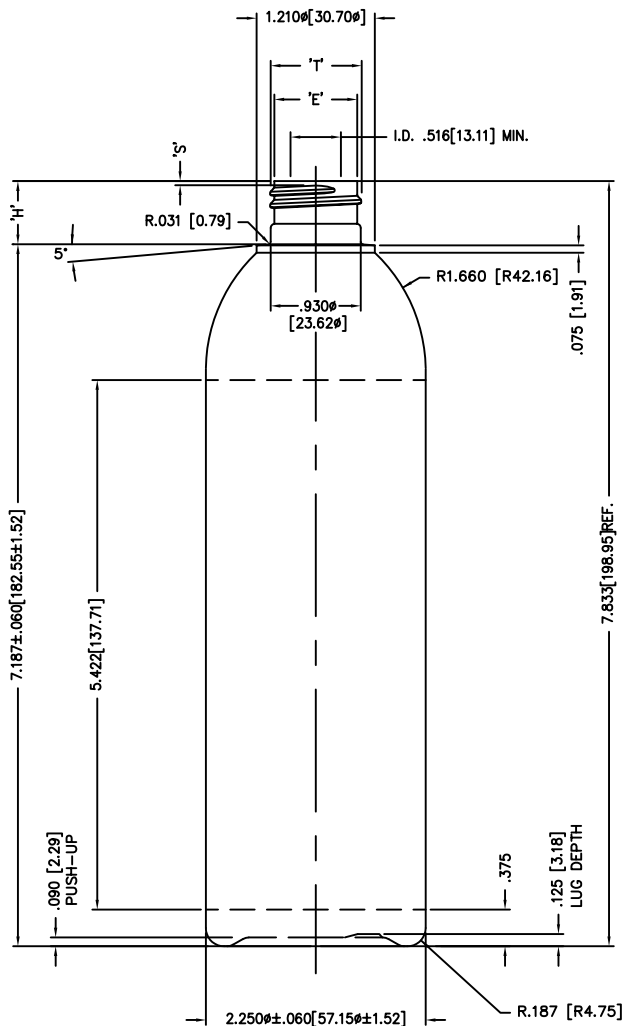

ALTERNATE NECK
M24-SP415
'T': .932 ± .008 [23.67 ± 0.20]
'E': .848 ± .008 [21.54 ± 0.20]
'H': .957 ± .015 [24.31 ± 0.38]
'L': .561 [14.25] MIN.
'S': .046 ± .015 [1.17 ± 0.38]
HELIX : 2°34'
T.P.I.: 8
CUTT. DIA.: .375 [9.52]
GRAM WT.: 28 ± 1.5
O/F/C: 419ml ± 11

NOTE:
.012 [0.30] MIN. WALL

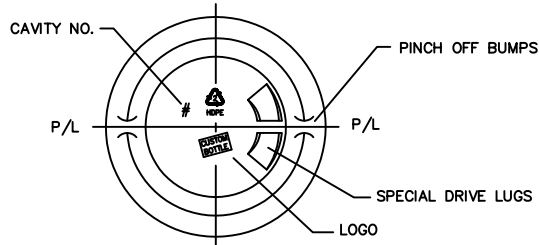

SCREEN PRINTING INFORMATION
MINIMUM BOTTLE CIRCUMFERENCE - 7.008
MUST ALLOW 5/16 BREAK IN COPY
TOTAL WIDTH OF COPY 6.696"
TOTAL HEIGHT OF COPY 5.422"

NO.	REV.	BY	DESCRIPTION	DATE	
NECK FINISH: M24 SP410			GRAM WT. 27 ± 1.5		
'T'	'E'	'H'	'S'	'L'	'I'
.932 ± .008	.848 ± .008	.646 ± .015	.046 ± .015	.437 MIN.	_____
23.67 ± 0.20	21.54 ± 0.20	16.41 ± 0.38	1.17 ± 0.38	11.10 MIN.	_____
HELIX <: 2° 34'		T.P.I.: 8	CUTT. DIA.: .375 [9.53]		
OVERFLOW CAPACITY BEFORE DECORATING				416ml ± 11	
			Custom Bottle Inc. 10 Great Hill Road P.O. Box 720 Naugatuck, Connecticut 06770 203-723-6661		
			DRAWN BY: 1130		
SCALE: 1-1			DATE: OCT.22/03		
BOTTLE MAT'L: HDPE			DRAWING NO.: 107-5844-STOCK		
C.B.I.D.: #373			MOULD NO.:		