

DISCLAIMER: CUSTOM BOTTLE INC.
ASSUMES NO RESPONSIBILITY FOR:
-FORM, FIT AND FUNCTION OF CLOSURES
-SHELF LIFE AND/OR COMPATIBILITY OF
INTENDED CONTENTS WITH THIS BOTTLE.

'T' AND 'E' DIMENSIONS ARE THE
AVERAGE OF TWO MEASUREMENTS
TAKEN 90° APART.
THE LIMITS OF QUALITY WILL BE
DETERMINED PER APPLICATION AS
NECESSARY.

DIMENSIONS IN [] ARE
IN MILLIMETERS
ALL OTHERS INDICATED
ARE IN INCHES
This drawing subject to
standard industry tolerances
S.P.I.

CUSTOM BOTTLE
APPROVAL:
APPROVED BY **BP**
DATE **NOV. 23/10**

CUSTOMER
APPROVAL:
APPROVED BY
DATE

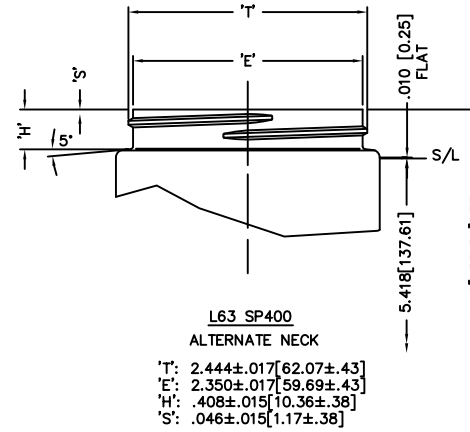
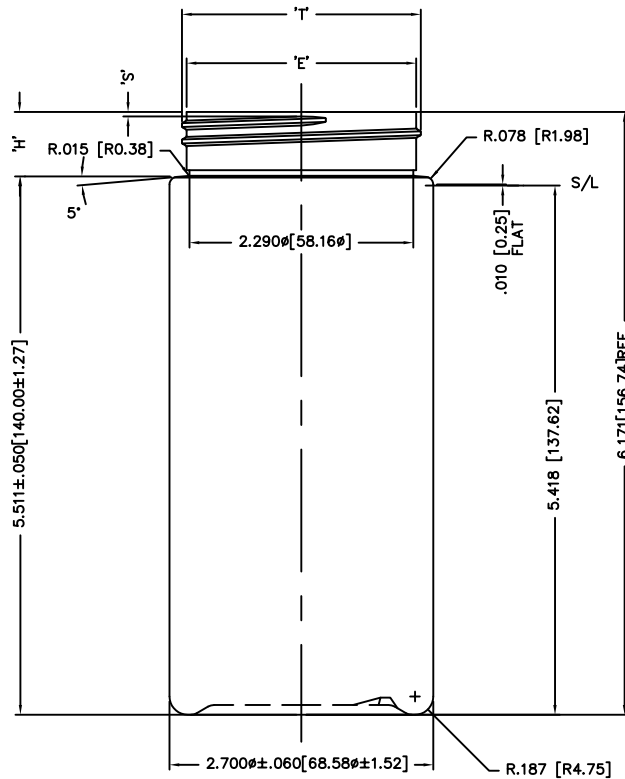

L63 SP400
ALTERNATE NECK
'T': 2.444±.017 [62.07±.43]
'E': 2.350±.017 [59.69±.43]
'H': .408±.015 [10.36±.38]
'S': .046±.015 [1.17±.38]
HELIX < : 1°16'
T.P.I.: 6
CUTT. DIA.: .500 [12.70]
GRAM WT. 31±2.0
O/F/C: 534ml±13
REF. NO.: 107-7958-6

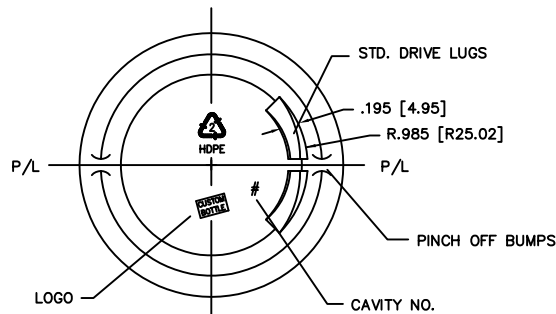

NO.	REV.	BY	DESCRIPTION	DATE	
NECK FINISH: L63 SP 485			GRAM WT. 31±2.0		
'T'	'E'	'H'	'S'	'L'	'I'
2.444 ±.017	2.350 ±.017	.660 ±.015	.046 ±.015	_____	_____
62.08 ±.043	59.69 ±.043	10.36 ±.038	1.17 ±.038	_____	_____
HELIX < : 1° 16'		T.P.I.: 6	CUTT. DIA.: .500		
OVERFLOW CAPACITY BEFORE DECORATING				534ml±13	
CUSTOM BOTTLE			Custom Bottle Inc. 10 Great Hill Road P.O. Box 720 Naugatuck, Connecticut 06770 203-723-6661		
DRAWN BY: 1130		DESC.: 16oz WIDE MOUTH CYL.			
SCALE: 1-1		DATE: JUNE.12/06		DRAWING NO.: 107-7016-STOCK	
BOTTLE MAT'L: HDPE		C.B.I.D.: #9		MOULD NO.:	