

'T' AND 'E' DIMENSIONS ARE THE AVERAGE OF TWO MEASUREMENTS TAKEN 90° APART.

THE LIMITS OF QUALITY WILL BE DETERMINED PER APPLICATION AS NECESSARY.

DIMENSIONS IN [] ARE IN MILLIMETERS ALL OTHERS INDICATED ARE IN INCHES

This drawing subject to standard industry tolerances S.P.I.

CUSTOM BOTTLE APPROVAL:
APPROVED BY **BP**
DATE **APR. 29/10**

DISCLAIMER: CUSTOM BOTTLE INC. ASSUMES NO RESPONSIBILITY FOR:
-FORM, FIT AND FUNCTION OF CLOSURES
-SHELF LIFE AND/OR COMPATIBILITY OF INTENDED CONTENTS WITH THIS BOTTLE.

CUSTOMER APPROVAL:
APPROVED BY
DATE

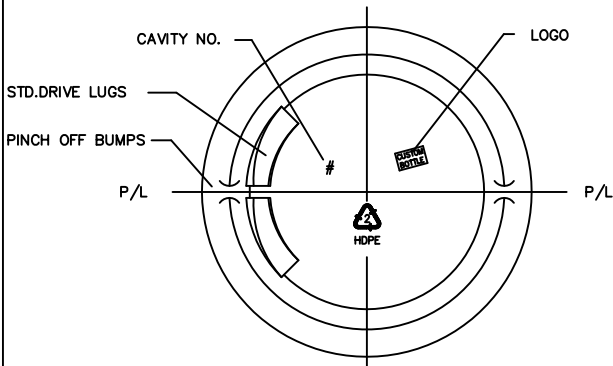

NO.	REV.	BY	DESCRIPTION	DATE	
NECK FINISH:			M28-SP415	GRAM WT. 63 ±3.5	
'T'	'E'	'H'	'S'	'L'	'I'
1.078 ±.010	.984 ±.010	1.082 ±.015	.046 ±.015	.655 MIN.	_____
27.38 ±0.25	24.99 ±0.25	27.48 ±0.38	1.17 ±0.38	16.64 MIN.	_____
HELIX <: 2' 57'		T.P.I.: 6	CUTT. DIA.: .500		
OVERFLOW CAPACITY BEFORE DECORATING					
CUSTOM BOTTLE			Custom Bottle Inc. 10 Great Hill Road P.O. Box 720 Naugatuck, Connecticut 06770 203-723-6661		
DRAWN BY:			DESC.: 1L COSMO		
SCALE: 1-1		DATE:		DRAWING NO.:	
BOTTLE MAT'L: HDPE		T		107-5862-STOCK	
C.B.I.D.: #102		MOULD NO.:			