

DISCLAIMER: CUSTOM BOTTLE INC.
 ASSUMES NO RESPONSIBILITY FOR:
 -FORM, FIT AND FUNCTION OF CLOSURES
 -SHELF LIFE AND/OR COMPATIBILITY OF
 INTENDED CONTENTS WITH THIS BOTTLE.

'T' AND 'E' DIMENSIONS ARE THE
 AVERAGE OF TWO MEASUREMENTS
 TAKEN 90° APART.
 THE LIMITS OF QUALITY WILL BE
 DETERMINED PER APPLICATION AS
 NECESSARY.

DIMENSIONS IN [] ARE
 IN MILLIMETERS
 ALL OTHERS INDICATED
 ARE IN INCHES
 This drawing subject to
 standard industry tolerances
 S.P.I.

CUSTOM BOTTLE
 APPROVAL:
 APPROVED BY **BP**
 DATE **APR. 29/10**
 CUSTOMER
 APPROVAL:
 APPROVED BY
 DATE

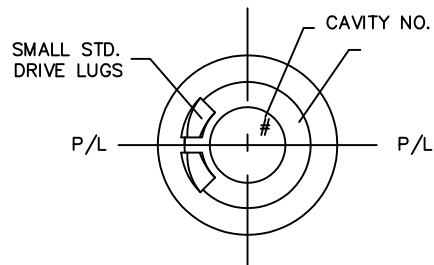
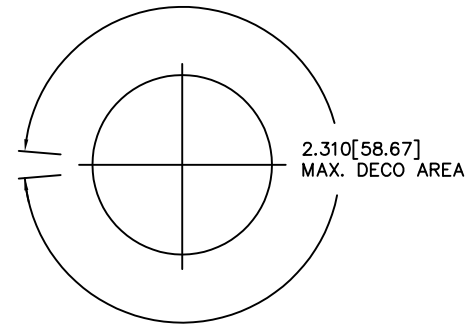
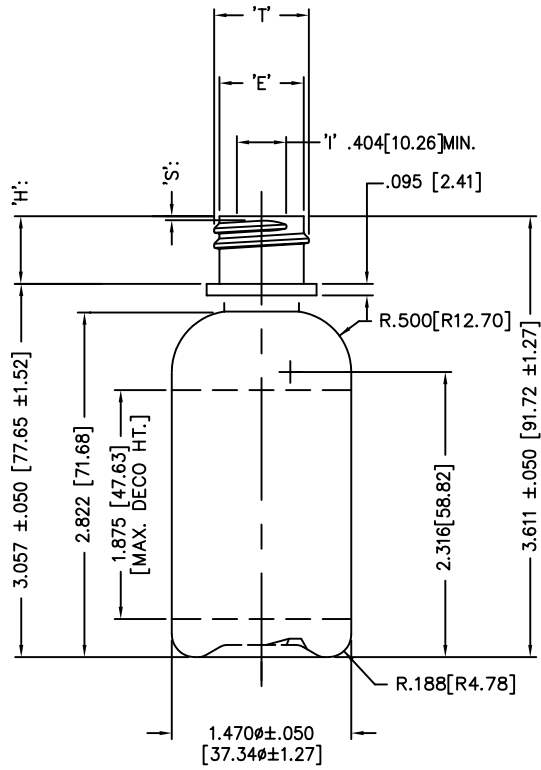

NO.	REV.	BY	DESCRIPTION	DATE	
NECK FINISH: M20 SP410			GRAM WT. 8 ± 1		
'T'	'E'	'H'	'S'	'L'	'I'
.775 ± 0.008	.691 ± 0.008	.554 ± 0.015	.037 ± 0.015	.361 MIN	_____
19.69 ± 0.20	17.55 ± 0.20	14.07 ± 0.38	0.94 ± 0.38	9.14 MIN.	_____
HELIX <: 3' 7'		T.P.I.: 8	CUTT. DIA.: .375 [9.53]		
OVERFLOW CAPACITY BEFORE DECORATING				72ml ± 4	
CUSTOM BOTTLE			Custom Bottle Inc. 10 Great Hill Road P.O. Box 720 Naugatuck, Connecticut 06770 203-723-6661		
DRAWN BY:		DESC.: 2oz BOSTON RD.-SHRINK BAND			
SCALE: 1-1	DATE: FEB.5/07		DRAWING NO.: 107-8268-STOCK		
BOTTLE MAT'L: HDPE/LDPE/PP		C.B.I.D.: #376			
		MOULD NO.:			