

DISCLAIMER: CUSTOM BOTTLE INC.  
ASSUMES NO RESPONSIBILITY FOR:  
-FORM, FIT AND FUNCTION OF CLOSURES  
-SHELF LIFE AND/OR COMPATIBILITY OF  
INTENDED CONTENTS WITH THIS BOTTLE.

'T' AND 'E' DIMENSIONS ARE THE  
AVERAGE OF TWO MEASUREMENTS  
TAKEN 90° APART.  
THE LIMITS OF QUALITY WILL BE  
DETERMINED PER APPLICATION AS  
NECESSARY.

DIMENSIONS IN [ ] ARE  
IN MILLIMETERS  
ALL OTHERS INDICATED  
ARE IN INCHES  
This drawing subject to  
standard industry tolerances  
S.P.I.

CUSTOM BOTTLE  
APPROVAL:  
APPROVED BY **BP**  
DATE **NOV. 23/10**  
CUSTOMER  
APPROVAL:  
APPROVED BY .....  
DATE .....

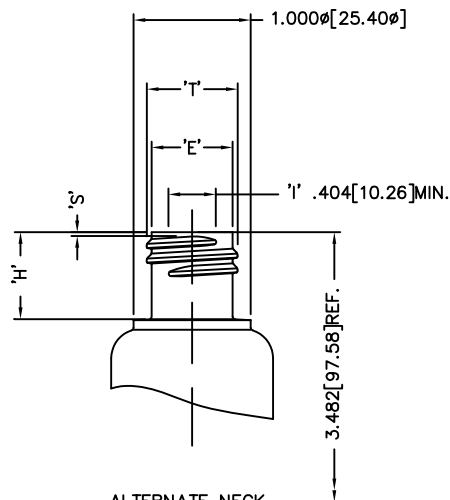
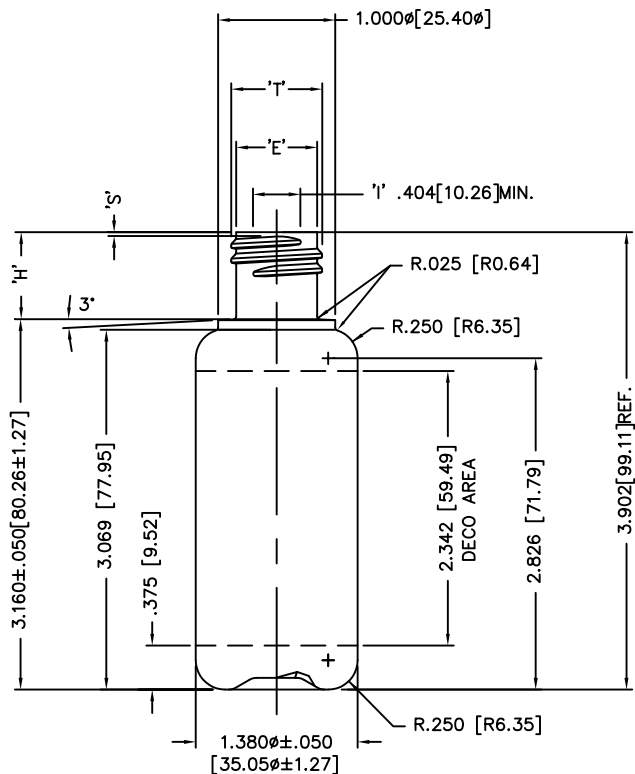

ALTERNATE NECK  
M20 SP415  
PLUG FINISH

'T': .775±.008 [19.68±.20]  
'E': .691±.008 [17.55±.20]  
'H': .682±.015 [17.32±.38]  
'I': .404 MIN. [10.26 MIN.]

HELIX : 3'7'  
T.P.I.: 8  
CUTT DIA.: .375 [9.53]  
GRAM WT.: 11±1.0  
O/F/C.: 67ml±3.5

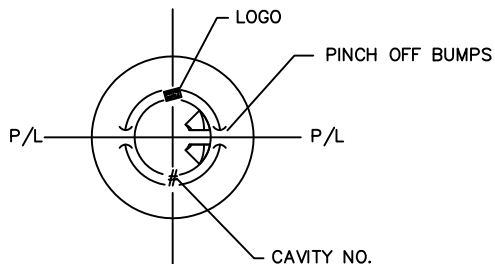

SCREEN PRINTING INFORMATION

BOTTLE CIRCUMFERENCE: 4.180 [106.17]  
MUST LEAVE .312 [7.92] BREAK  
TOTAL WIDTH OF COPY: 3.870 [98.30]  
TOTAL HEIGHT OF COPY: 2.340 [59.44]

NO.	REV.	BY	DESCRIPTION	DATE	
NECK FINISH: M20 SP415			GRAM WT. 11±1.0		
'T'	'E'	'H'	'S'	'L'	'I'
.775 ±.008	.691 ±.008	.742 ±.015	.037 ±.015	.361 MIN	.404 MIN.
19.69 ±0.20	17.55 ±0.20	18.84±.38	0.94 ±0.38	9.14 MIN.	10.26 MIN.
HELIX <: 3' 7'		T.P.I.: 8	CUTT. DIA.: .375 [9.53]		
OVERFLOW CAPACITY BEFORE DECORATING				67.2ml±3.5	

**CUSTOM BOTTLE** Custom Bottle Inc.  
10 Great Hill Road  
P.O. Box 720  
Naugatuck, Connecticut 06770  
203-723-6661

DRAWN BY: 1130	DESC.: 2oz. MALIBU RD.
SCALE: 1-1	DATE: SEPT.09/05
BOTTLE MAT'L: HDPE/LDPE	DRAWING NO.: 107-6974-STOCK
C.B.I.D.: #15	MOULD NO.: