

**NOTE:**  
MIN. WALL THICKNESS .015 [0.38]

DISCLAIMER: CUSTOM BOTTLE INC.  
ASSUMES NO RESPONSIBILITY FOR:  
-FORM, FIT AND FUNCTION OF CLOSURES  
-SHELF LIFE AND/OR COMPATIBILITY OF  
INTENDED CONTENTS WITH THIS BOTTLE.

'T' AND 'E' DIMENSIONS ARE THE  
AVERAGE OF TWO MEASUREMENTS  
TAKEN 90° APART.  
THE LIMITS OF QUALITY WILL BE  
DETERMINED PER APPLICATION AS  
NECESSARY.

DIMENSIONS IN [ ] ARE  
IN MILLIMETERS  
ALL OTHERS INDICATED  
ARE IN INCHES  
This drawing subject to  
standard industry tolerances  
S.P.I.

CUSTOM BOTTLE  
APPROVAL:  
APPROVED BY **BP**  
DATE **NOV. 23/10**

CUSTOMER  
APPROVAL:  
APPROVED BY .....  
DATE .....

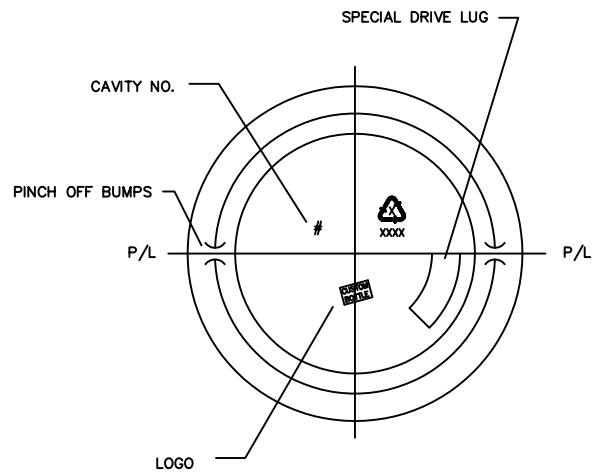

NO.	REV.	BY	DESCRIPTION	DATE	
NECK FINISH: M28 SP410			GRAM WT. 52 ± 2.5		
'T'	'E'	'H'	'S'	'L'	'I'
1.078 ± .010	.984 ± .010	.708 ± .015	.046 ± .015	.463 MIN.	_____
27.38 ± 0.25	24.99 ± 0.25	17.98 ± 0.38	1.17 ± 0.38	11.94 MIN.	_____
HELIX <: 2' 57'		T.P.I.: 6	CUTT. DIA.: .500 [12.70]		
OVERFLOW CAPACITY BEFORE DECORATING				1008ml ± 15	
			Custom Bottle Inc. 10 Great Hill Road P.O. Box 720 Naugatuck, Connecticut 06770 203-723-6661		
			DRAWN BY: 1130		
SCALE: 1-1		DATE: MAR.3/06		DRAWING NO.: 107-7256-STOCK	
BOTTLE MAT'L: HDPE			C.B.I.D.: #299		
			MOULD NO.:		

**SCREEN PRINTING INFO.:**

MAX. HEIGHT: 4.650 [118.11]  
MAX. WIDTH: 9.900 [251.46]

(LEAVING .312 [7.91] BREAK IN COPY)