

DISCLAIMER: CUSTOM BOTTLE INC.  
ASSUMES NO RESPONSIBILITY FOR:  
-FORM, FIT AND FUNCTION OF CLOSURES  
-SHELF LIFE AND/OR COMPATIBILITY OF  
INTENDED CONTENTS WITH THIS BOTTLE.

"T" AND "E" DIMENSIONS ARE THE  
AVERAGE OF TWO MEASUREMENTS  
TAKEN 90° APART.  
THE LIMITS OF QUALITY WILL BE  
DETERMINED PER APPLICATION AS  
NECESSARY.

DIMENSIONS IN [ ] ARE  
IN MILLIMETERS  
ALL OTHERS INDICATED  
ARE IN INCHES  
This drawing subject to  
standard industry tolerances  
S.P.I.

CUSTOM BOTTLE  
APPROVAL:  
APPROVED BY **BP**  
DATE **NOV. 23/10**  
CUSTOMER  
APPROVAL:  
APPROVED BY .....  
DATE .....

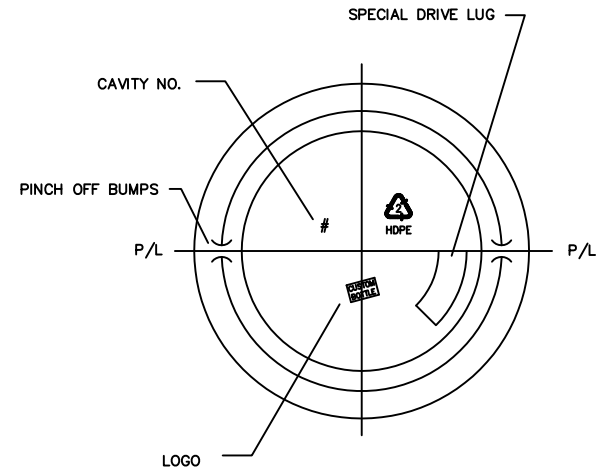
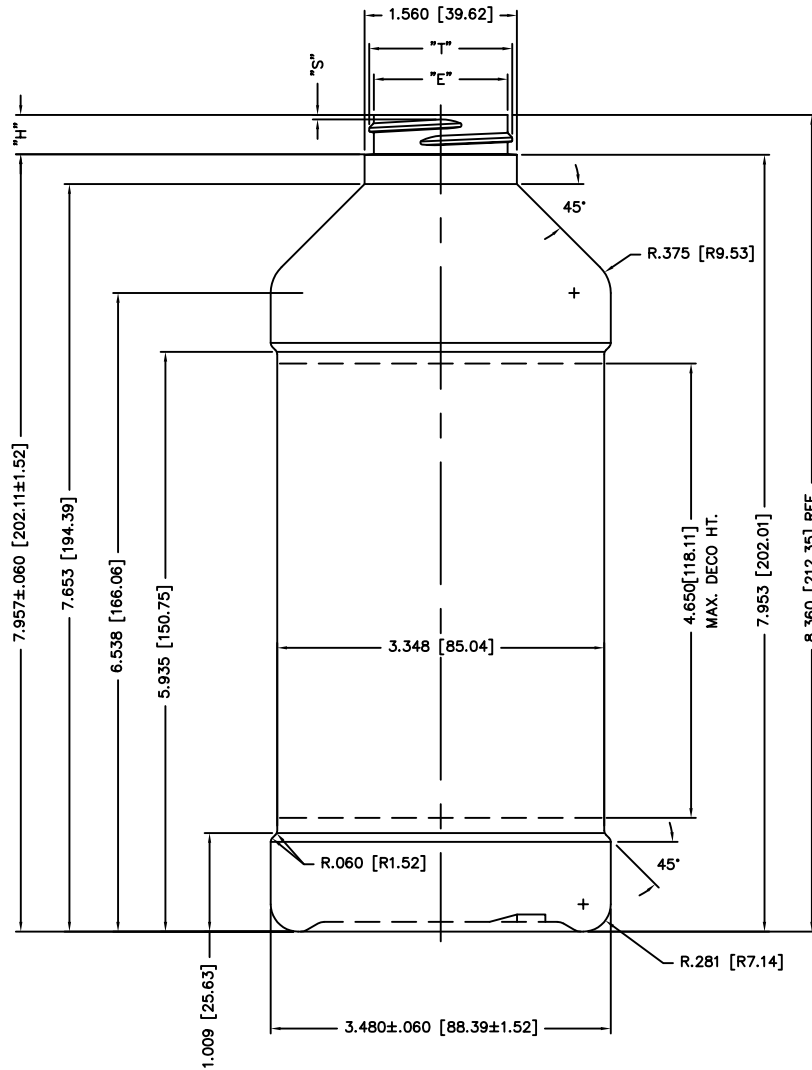

NO.	REV.	BY	DESCRIPTION	DATE	
NECK FINISH: M38 SP400			GRAM WT. 50 ±2.5		
'T'	'E'	'H'	'S'	'L'	'I'
1.464 ±.010	1.370 ±.010	.403 ±.015	.046 ±.015	—	.987 MIN.
37.19 ±0.25	34.80 ±0.25	10.24 ±0.38	1.17 ±0.38	—	25.07 MIN.
HELIX <: 2' 09'		T.P.I.: 6	CUTT. DIA.: .500[12.70]		
OVERFLOW CAPACITY BEFORE DECORATING				1022ml ±15	
<b>CUSTOM BOTTLE</b>			Custom Bottle Inc. 10 Great Hill Road P.O. Box 720 Naugatuck, Connecticut 06770 203-723-6661		
DRAWN BY: 1130		DESC.: 32oz MODERN ROUND			
SCALE: 1-1	DATE: MAR.13/06				
BOTTLE MAT'L: HDPE		DRAWING NO.: 107-V10430-STOCK			
C.B.I.D.: #3		MOULD NO.:			

SCREEN PRINTING INFO.:

MAX. HEIGHT: 4.650 [118.11]  
MAX. WIDTH: 9.900 [251.46]

(LEAVING .312 [7.91] BREAK IN COPY)