

DISCLAIMER: CUSTOM BOTTLE INC.
ASSUMES NO RESPONSIBILITY FOR:
-FORM, FIT AND FUNCTION OF CLOSURES
-SHELF LIFE AND/OR COMPATIBILITY OF
INTENDED CONTENTS WITH THIS BOTTLE.

'T' AND 'E' DIMENSIONS ARE THE
AVERAGE OF TWO MEASUREMENTS
TAKEN 90° APART.
THE LIMITS OF OVALITY WILL BE
DETERMINED PER APPLICATION AS
NECESSARY.

DIMENSIONS IN [] ARE
IN MILLIMETERS
ALL OTHERS INDICATED
ARE IN INCHES
THIS DRAWING SUBJECT TO
STANDARD INDUSTRY
TOLERANCES S.P.I.

CUSTOM BOTTLE
APPROVAL:
Approved BY **B.P.**
Date: ...**MAR.16/11**

CUSTOMER
APPROVAL:
Approved BY
Date:

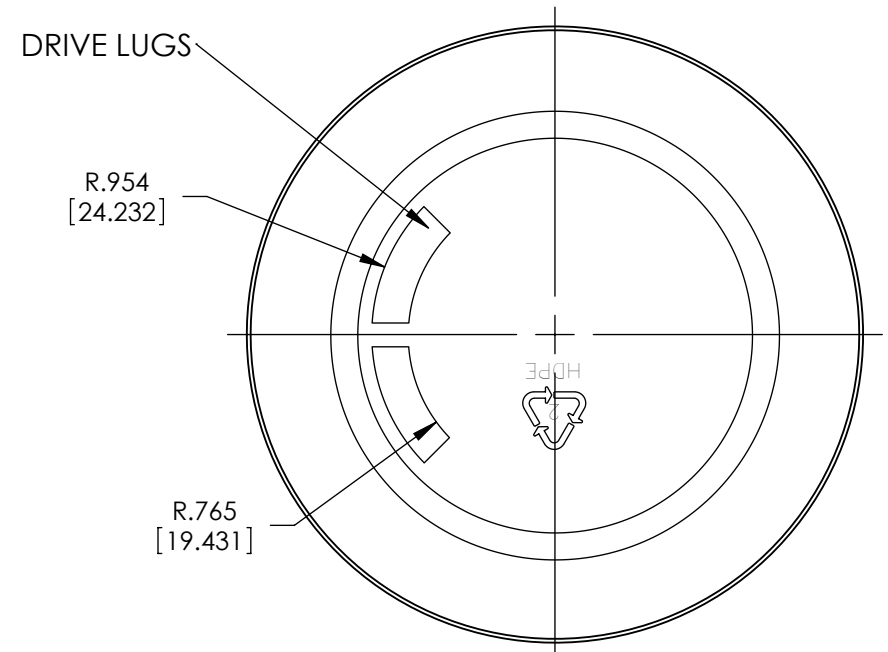
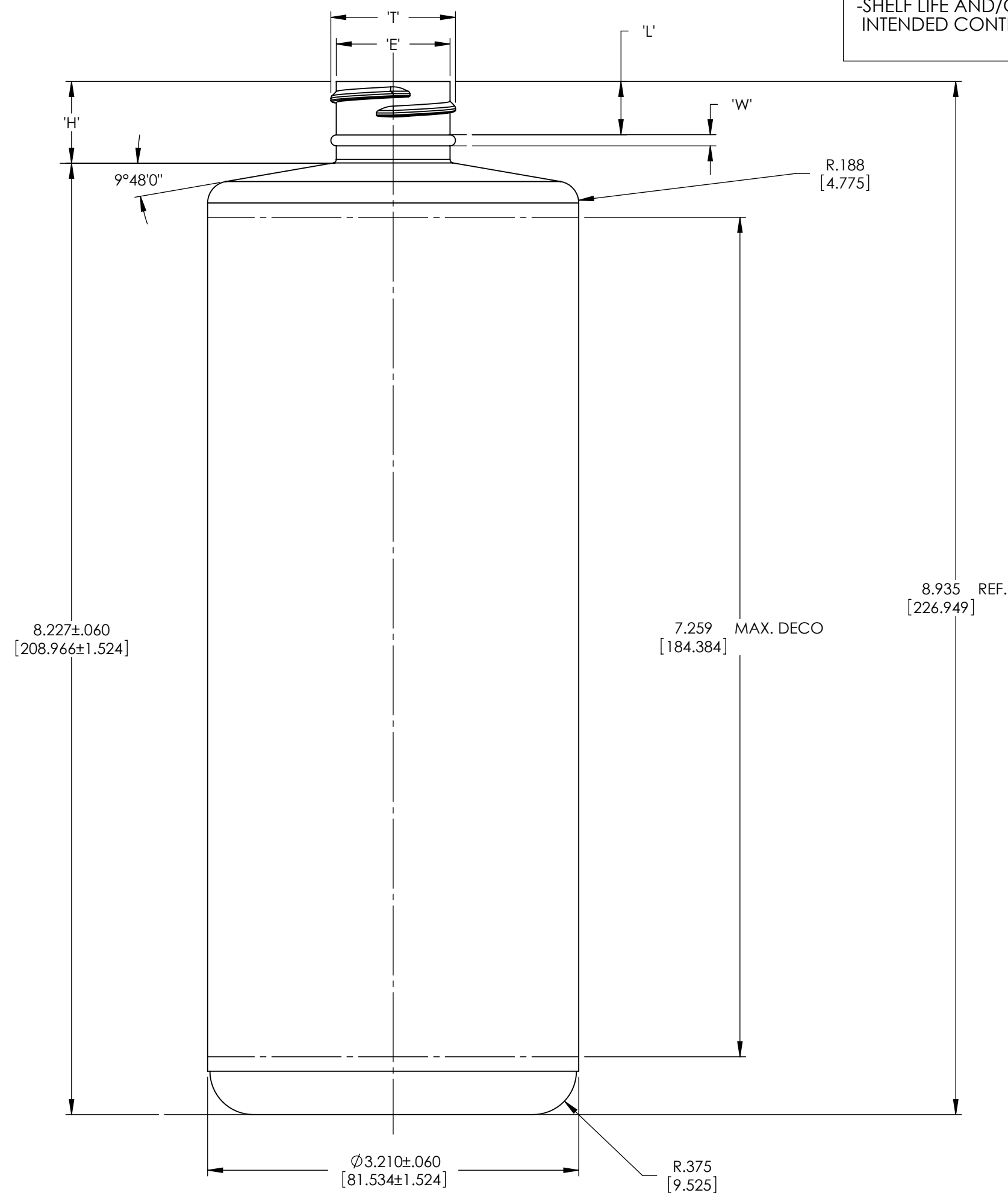

No.	Rev.No.	Description	Date		
Neck Finish:		M28-SP410	Gram Wt.: 55 ±3		
'T'	'E'	'H'	'S'	'L'	'W'
1.078 ±.010	.984 ±.010	.708 ±.015	.046 ±.015	.463 MIN.	_____
27.38 ±0.25	25.00 ±0.25	17.98 ±0.38	1.17 ±0.38	11.76 MIN.	_____
HELIX ANGLE: 2° 57'		T.P.I.: 6	CUTT. DIA.: .500 [12.70]		
Overflow capacity before decorating				1017ml ±15	
		Custom Bottle Inc. 10 Great Hill Road P.O. Box 720 Naugatuck, Connecticut 06770 203-723-6661			
		Drawn By: 1130	Desc. 32oz. SQUAT CYLINDER		
Scale: 1-1	Date: JUNE19/07	Drawing No. 107-7866-A-STOCK			
Bottle Mat'l: HDPE	Mould No.				
C.B.I.D.: #99					