

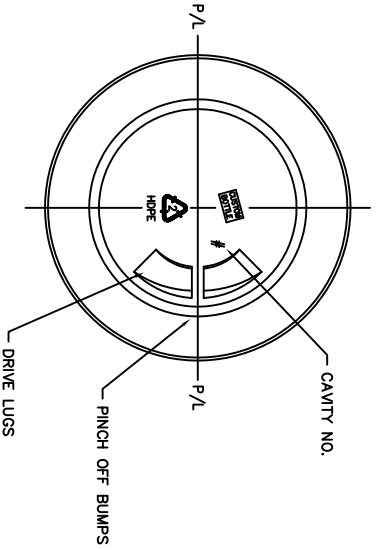

CUSTOM BOTTLE  
 APPROVAL: **APPROVED**  
 NECK FINISH: .....  
 WEIGHT: .....  
 CAPACITY: .....  
 MATERIAL: .....  
 SPECIAL REQUESTS: .....  
 CUSTOMER APPROVAL: .....  
 APPROVED BY: .....  
 DATE: .....

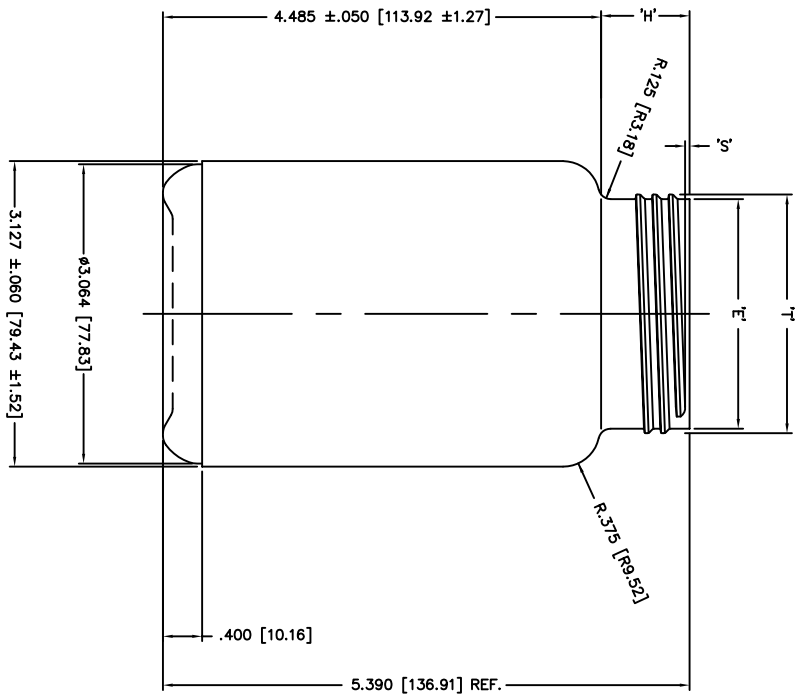

This drawing subject to standard industry tolerances S.P.L.

NO.	REV.	BY	DESCRIPTION	GRAM WT.	34 ±2	DATE
NECK FINISH: M63-SP400 (SPECIAL)						
1						
2	444 ±.017	2.350 ±.017	.905 ±.015	.046 ±.015		
3	2.08 ±0.43	59.69 ±0.43	23.00 ±0.38	1.17 ±0.38		
HELIX <: 1' 16' T.P.L.: 6 CUTT. DIA.: .500						
CAPACITY TO FILL LEVEL BEFORE DECORATING 500ml ±11						
CAPACITY TO FILL LEVEL AFTER DECORATING _____						
OVERFLOW CAPACITY BEFORE DECORATING _____						
OVERFLOW CAPACITY AFTER DECORATING 573ml ±13						
 Custom Bottle Inc. 10 Great Hill Road P.O. Box 720 Naugatuck, Connecticut 06770 203-723-6300						
DRAWN BY: 1130						
SCALE: 1-1 DATE: MAR. 10/09						
BOTTLE MAT'L: HDPE						
DESC.: 500cc W/M PHARMA RD.						
DRAWING NO.: 107-8495-P						
C.B.I.D.: #143						