

CUSTOM BOTTLE APPROVAL:  
 NECK FINISH .....  
 WEIGHT .....  
 CAPACITY .....  
 MATERIAL .....  
 SPECIAL REQUESTS .....  
 CUSTOMER APPROVAL:  
 APPROVED BY .....  
 DATE .....

APPROVED

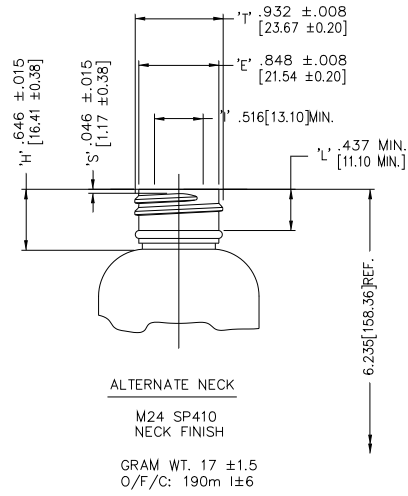
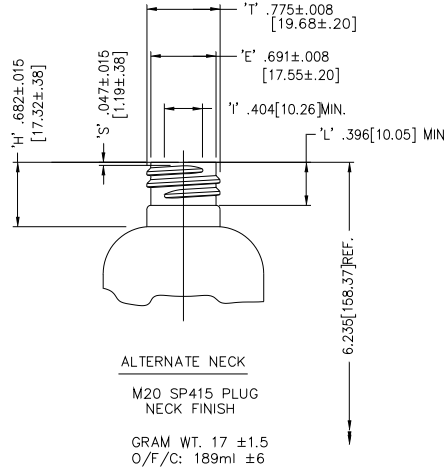
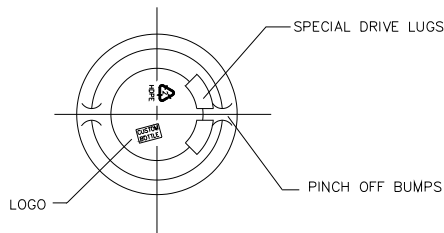
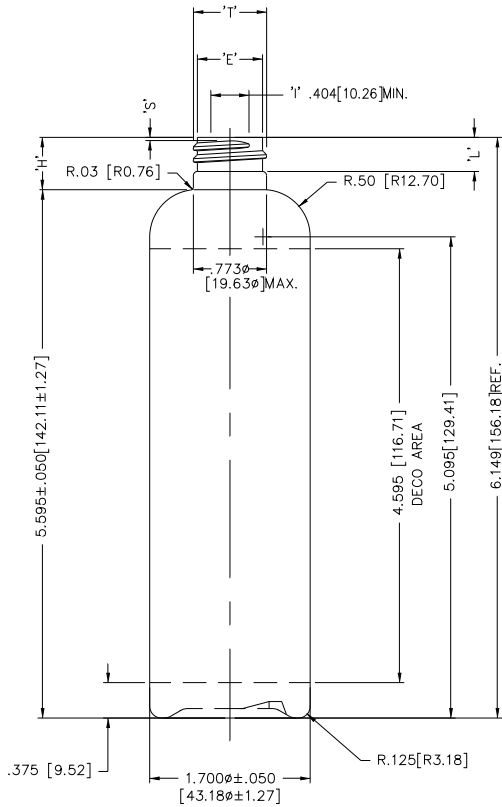

NOTE: SCREEN PRINTING INFO:  
 MAX. HEIGHT 4.595 [116.71]  
 MAX. WIDTH 4.872 [123.75] (LEAVING 5/16" BREAK IN COPY)

NO.	REV.	BY	DESCRIPTION	DATE	
NECK FINISH: M20 SP410			GRAM WT. 17±1.5		
T'	E'	H'	S'	L'	I'
.775 ±.008	.691 ±.008	.554 ±.015	.037 ±.015	.361 MIN.	_____
19.69 ±0.20	17.55 ±0.20	14.07 ±0.38	0.94 ±0.38	9.14 MIN.	_____
HELIX <: 3' 7'		T.P.I.: 8	CUTT. DIA.: .375 [9.53]		
CAPACITY TO FILL LEVEL BEFORE DECORATING				177ml±6	
CAPACITY TO FILL LEVEL AFTER DECORATING				_____	
OVERFLOW CAPACITY BEFORE DECORATING				187.5ml±6	
OVERFLOW CAPACITY AFTER DECORATING				_____	



Custom Bottle Inc.  
 10 Great Hill Road  
 P.O. Box 720  
 Naugatuck, Connecticut 06770  
 203-723-6681

DRAWN BY: 002	DESC.: 6oz COSMO
SCALE: 1-1	DATE: oct.11/06
BOTTLE MAT'L: HDPE	DRAWING NO.: 107-7503-P
CAD NAME: PD\	C.B.I.D.: #203

This drawing subject to standard industry tolerances S.P.L.