

Drawing checked specifically for:

Neck finish:

Weight:

Capacity:

Material:

Special Requests:

Product design to be approved before mould cavities are machined.

Approved BY

Date:

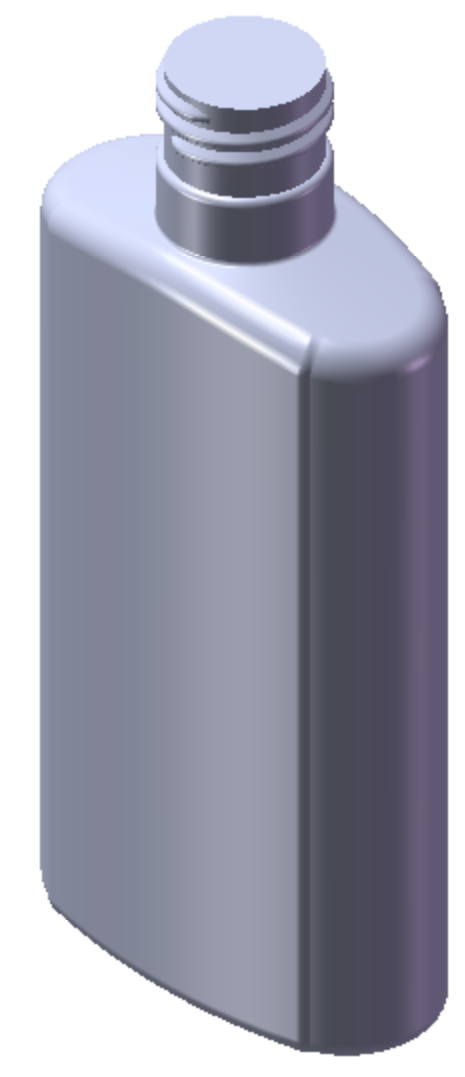
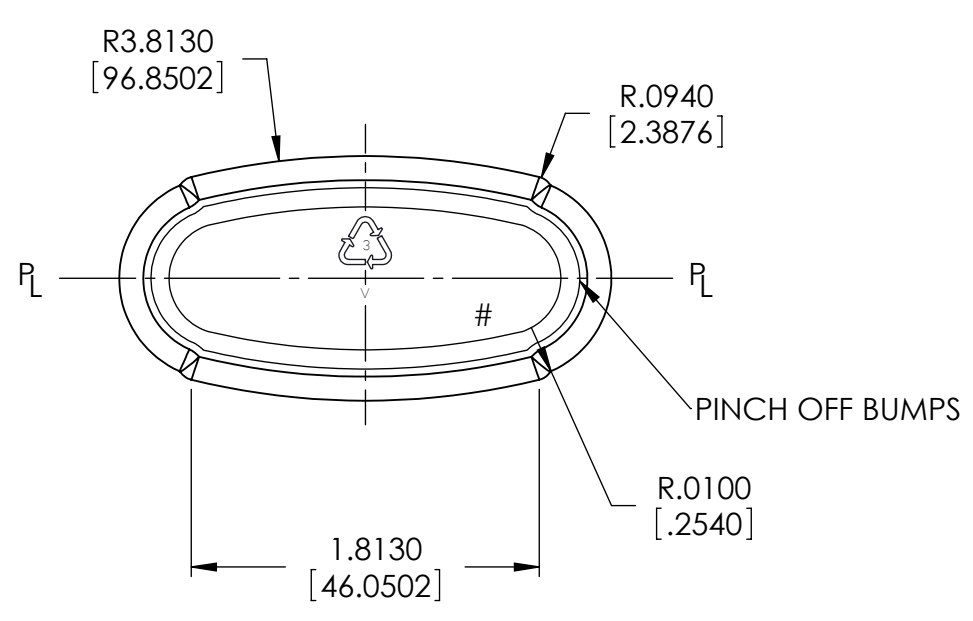
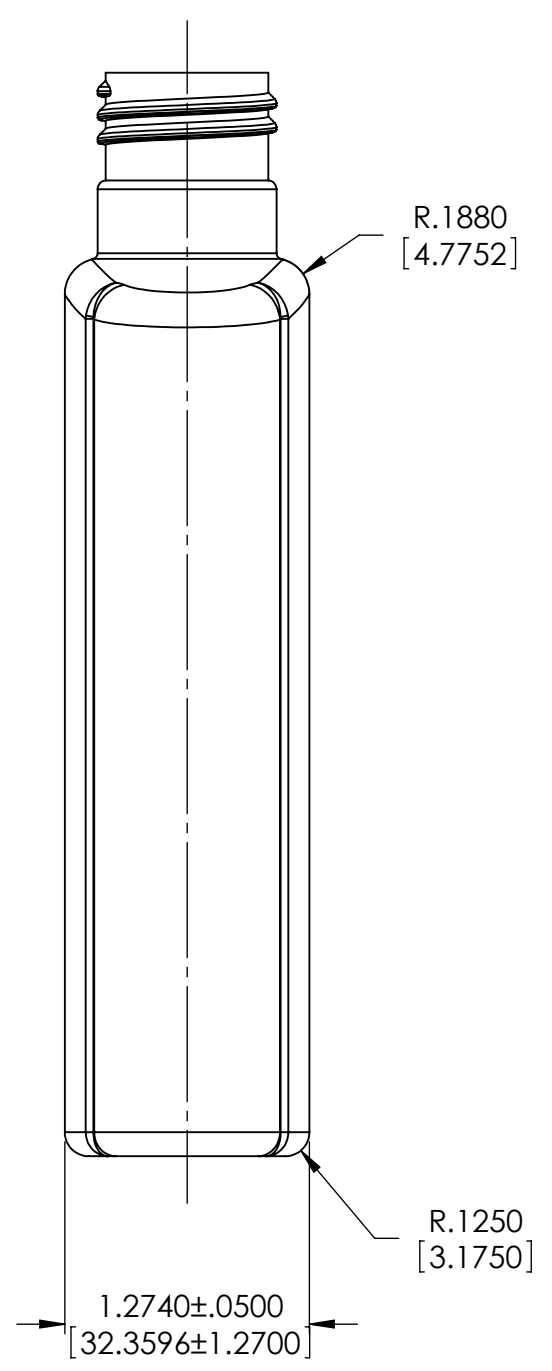
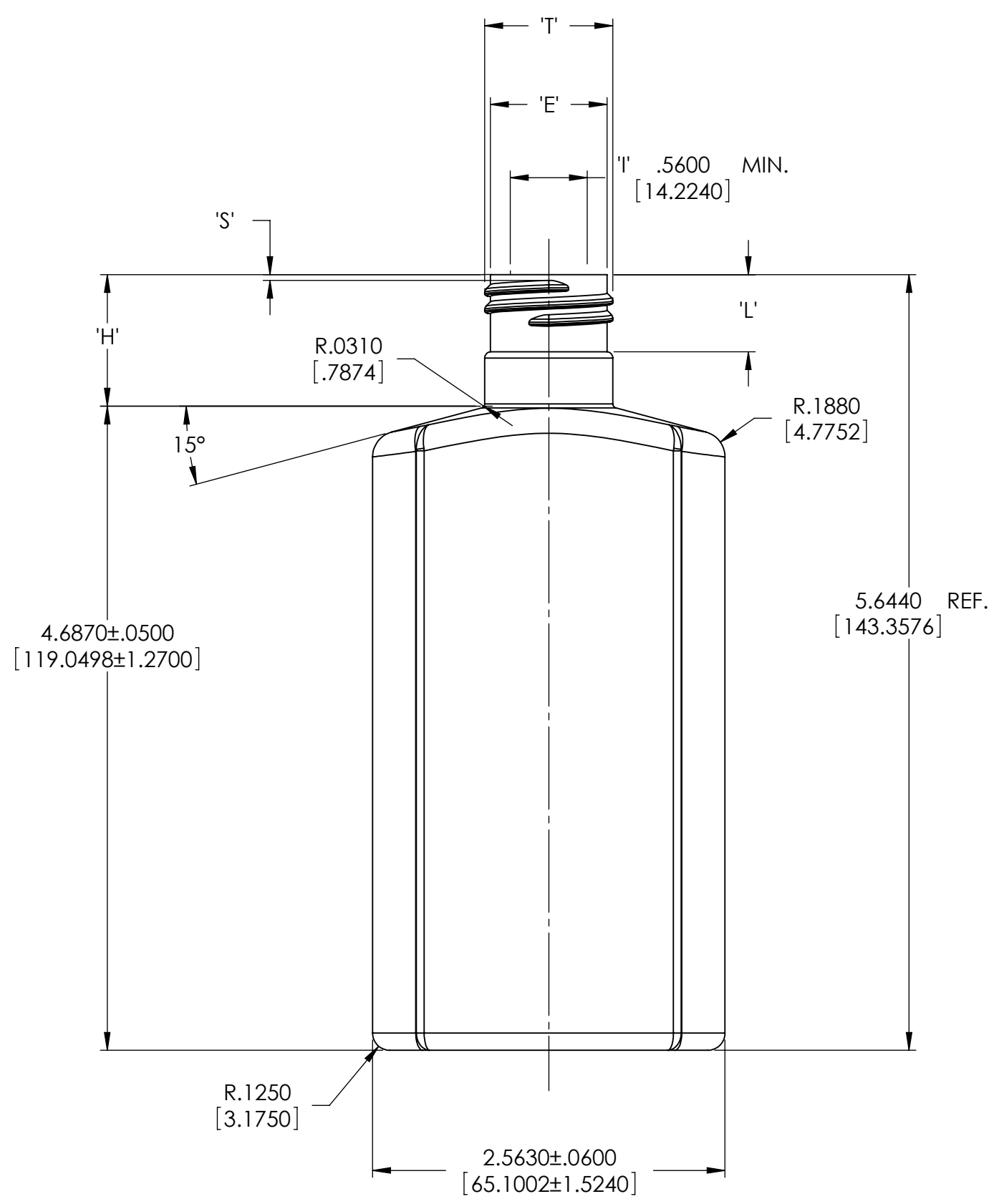

No.	Rev.No.	Description	Date		
Neck Finish: M24-SP415		Gram Wt.: 22 ±2			
'T'	'E'	'H'	'S'	'L'	'W'
.932 ±.008	.848 ±.008	.957 ±.015	.041 ±.010	.561 MIN.	_____
23.67 ±0.20	21.54 ±0.20	24.31 ±0.38	1.04 ±0.25	14.25 MIN.	_____
HELIX ANGLE: 2° 34'		T.P.I.: 8	CUTT. DIA.: .375 [9.53]		
Capacity to fill level before decorating		177ml ±5			
Capacity to fill level after decorating		_____			
Overflow Capacity before decorating		193.3ml ±5			
Overflow capacity after decorating		_____			
		Custom Bottle Inc. 10 Great Hill Road P.O. Box 720 Naugatuck, Connecticut 06770 203-723-6681			
		Drawn By: 001 Scale: 1-1 Date: JULY 15/08 Bottle Mat'l: PVC Mould No.:		Desc. 6oz. LOTION OVAL Drawing No. 107-8294-P C.B.I.D.: #58	

This drawing subject to standard industry tolerances S.P.I