

Drawing checked specifically for:

Neck finish:

Weight:

Capacity:

Material:

Special Requests:

Product design to be approved before mould cavities are machined.

Approved BY

Date:

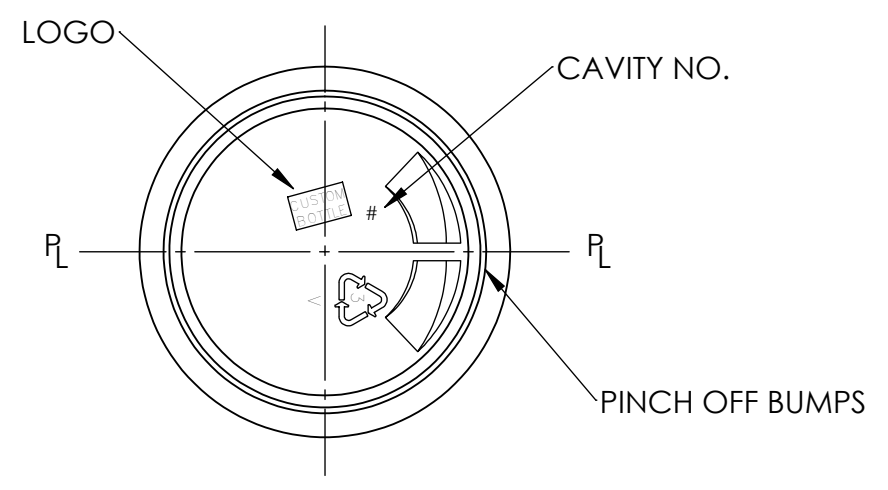
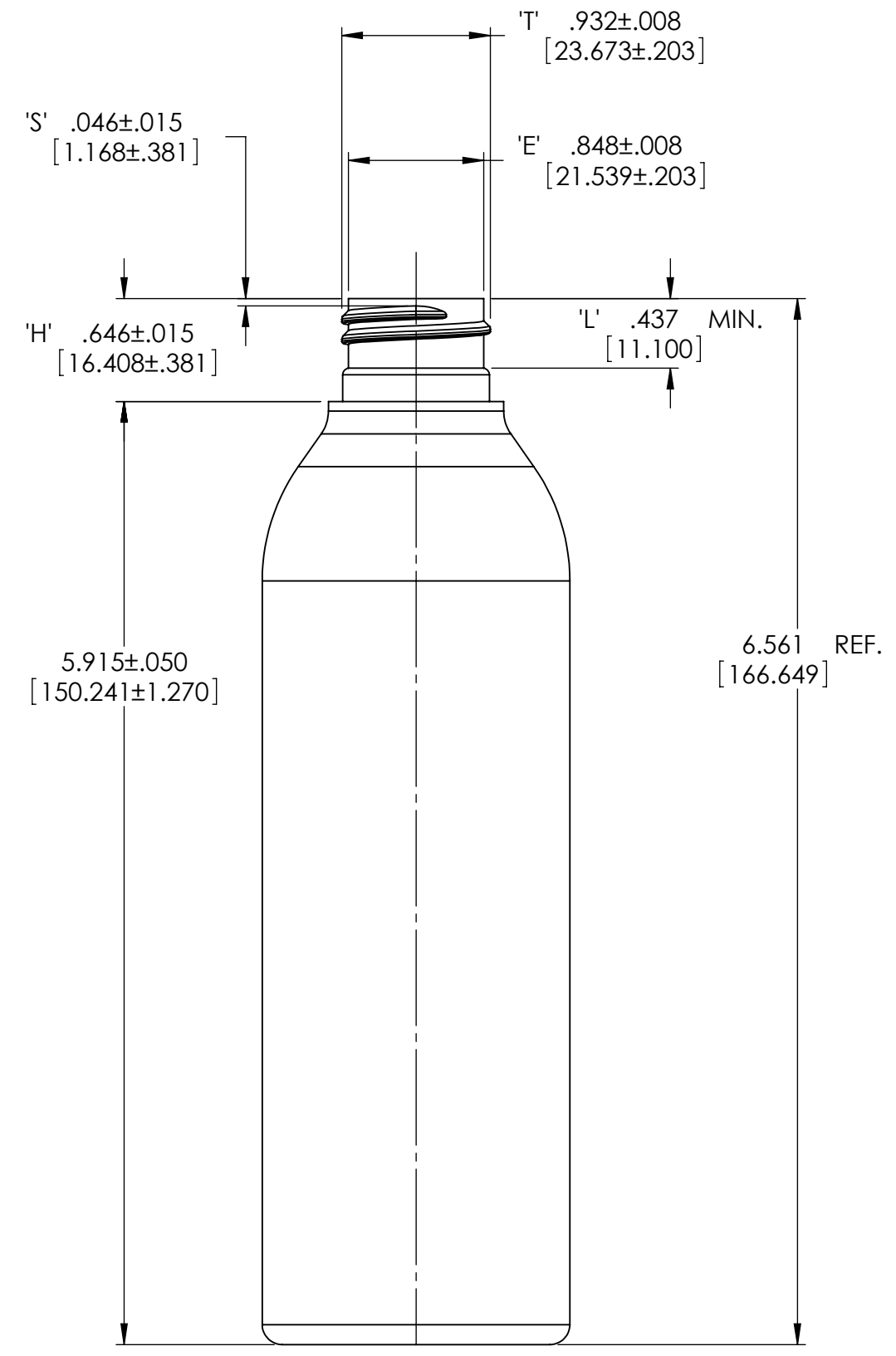
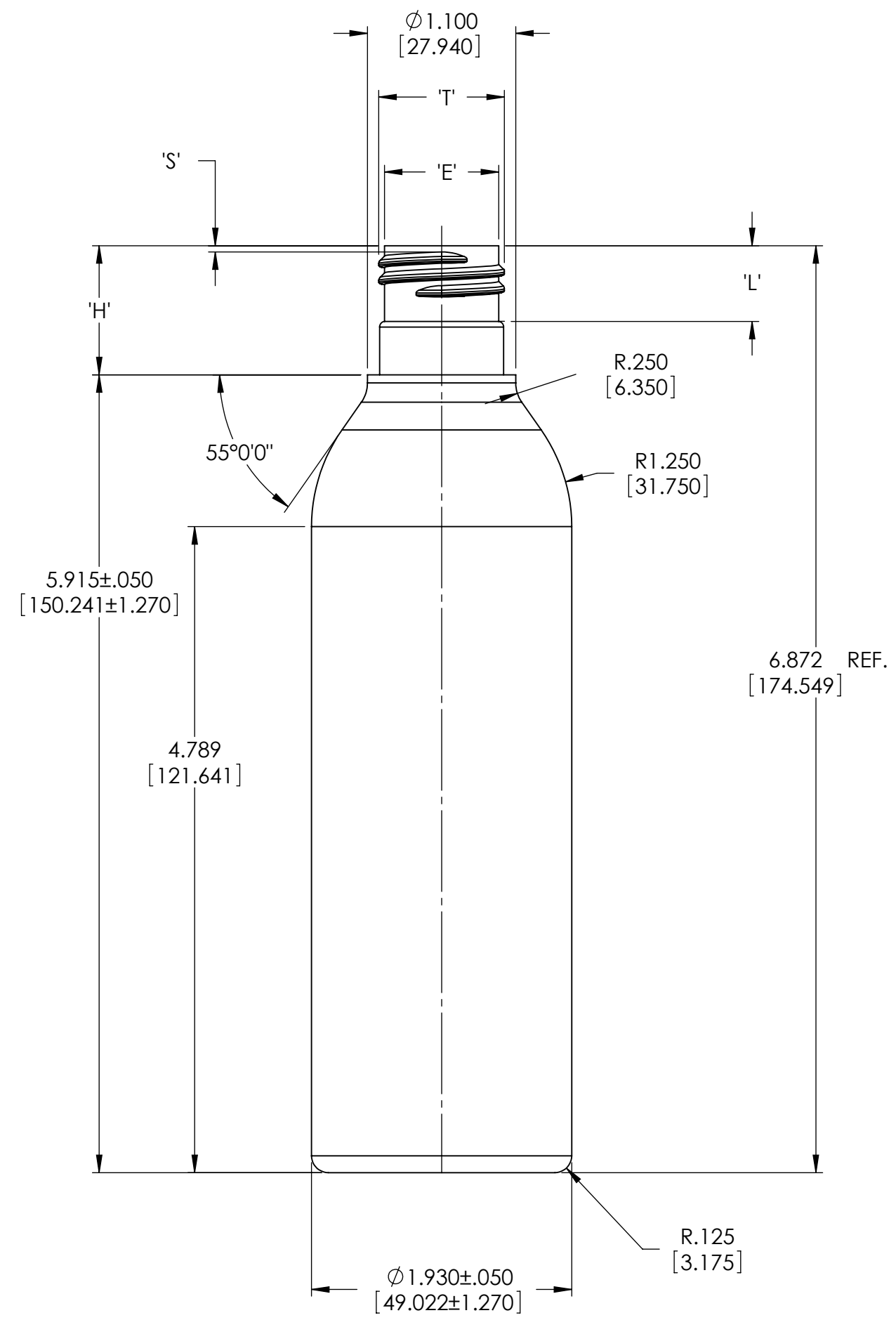

No.	Rev.No.	Description	Date		
Neck Finish: M24-SP415		Gram Wt.: 24 ±1.5			
'T'	'E'	'H'	'S'	'L'	'W'
.932 ±.008	.848 ±.008	.957 ±.015	.046 ±.015	.561 MIN.	_____
23.67 ±0.20	21.53 ±0.20	24.30 ±0.38	1.17 ±0.38	14.25 MIN.	_____
HELIX ANGLE: 2° 34'		T.P.I.: 8	CUTT. DIA.: .375 [9.52]		
Capacity to fill level before decorating		236ml ±7			
Capacity to fill level after decorating		_____			
Overflow Capacity before decorating		256ml ±7			
Overflow capacity after decorating		_____			
		Custom Bottle Inc. 10 Great Hill Road P.O. Box 720 Naugatuck, Connecticut 06770 203-723-6681			
		Drawn By: 001		Desc. 8oz. MILLENNIUM ROUND	
Scale: 1-1		Date: AUG.15/07		Drawing No. 107-7942-P	
Bottle Mat'l: HDPE		Cad Name:		C.B.I.D.: #256	

This drawing subject to standard industry tolerances S.P.I