

DISCLAIMER: CUSTOM BOTTLE INC.
ASSUMES NO RESPONSIBILITY FOR:
-FORM, FIT AND FUNCTION OF CLOSURES
-SHELF LIFE AND/OR COMPATIBILITY OF
INTENDED CONTENTS WITH THIS BOTTLE.

'T' AND 'E' DIMENSIONS ARE THE
AVERAGE OF TWO MEASUREMENTS
TAKEN 90° APART.
THE LIMITS OF QUALITY WILL BE
DETERMINED PER APPLICATION AS
NECESSARY.

DIMENSIONS IN [] ARE
IN MILLIMETERS
ALL OTHERS INDICATED
ARE IN INCHES
This drawing subject to
standard industry tolerances
S.P.I.

CUSTOM BOTTLE
APPROVAL:
APPROVED BY **BP**
DATE **NOV. 23/10**
CUSTOMER
APPROVAL:
APPROVED BY
DATE

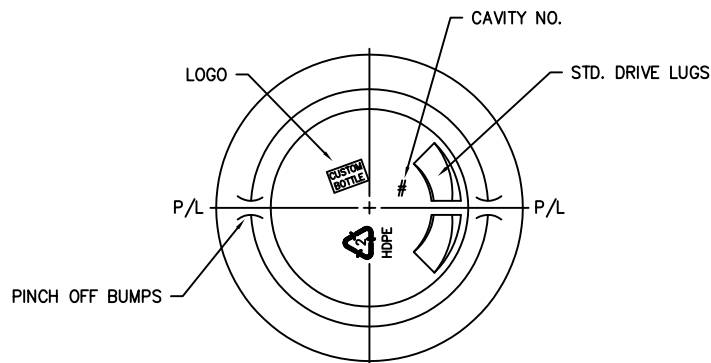
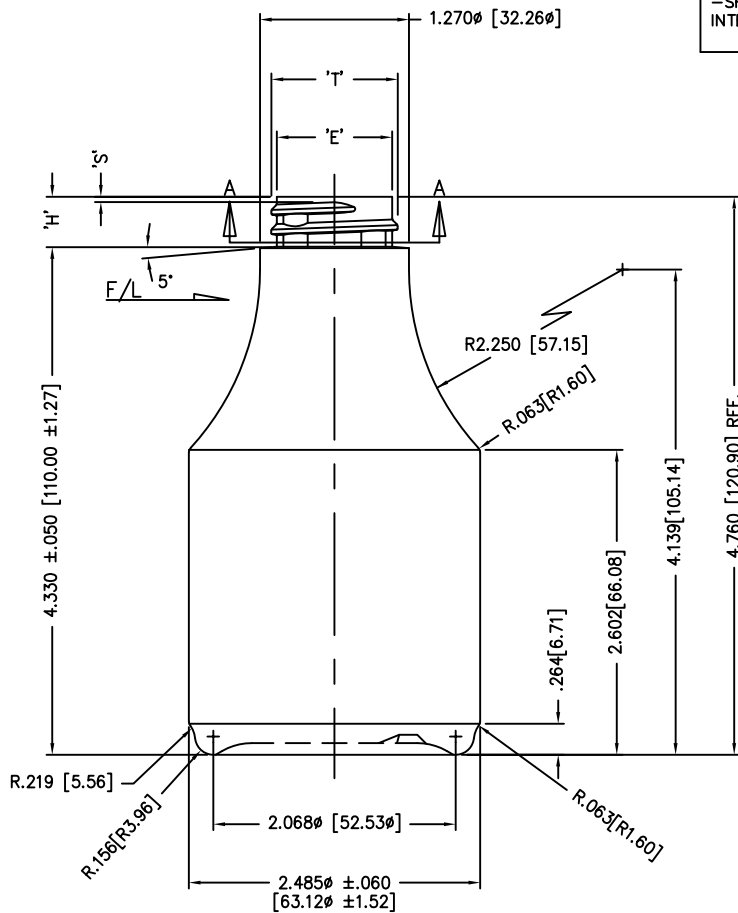

NO.	REV.	BY	DESCRIPTION			DATE
NECK FINISH: M28 SP400 (SPECIAL)			GRAM WT. 22±1.5			
'T'	'E'	'H'	'S'	'L'	'I'	
1.078 ± 0.010	.984 ± 0.010	.430 ± 0.015	.068 ± 0.015			
27.38 ± 0.25	24.99 ± 0.25	10.92 ± 0.38	1.73 ± 0.38			
HELIX <: 2° 57'		T.P.I.: 6	CUTT. DIA.: .500			
OVERFLOW CAPACITY BEFORE DECORATING			242 ml ± 7			
CUSTOM BOTTLE		Custom Bottle Inc. 10 Great Hill Road P.O. Box 720 Naugatuck, Connecticut 06770 203-723-6661				
DRAWN BY: 1130		DESC.: 8oz. SPRAYER RD.				
SCALE: 1-1		DATE: 29/7/97		DRAWING NO.: 107-3352-STOCK		
BOTTLE MAT'L: HDPE		C.B.I.D.: #211				
		MOULD NO.:				